

SPK Bluetooth 4.0 LE

Single Mode module datasheet

Doc. Version : 20140218

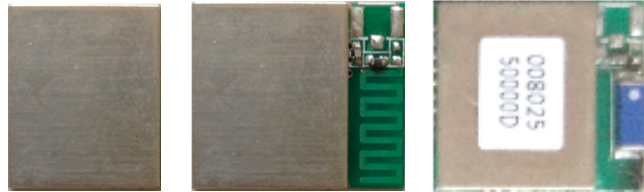

Product ID	EBM-A20A/B/C
Product Name	Bluetooth 4.0 LE single mode module
Firmware Version	
Hardware Version	Rev.1.0.2

1. DESCRIPTION

Bluetooth v4.0 Low Energy specifies two types(single mode and dual mode) of implementation.

Single mode chips implement the low energy specification and consume a fraction of the power of classic Bluetooth to allow the short-range wireless standard to extend to coin cell battery applications. Single mode BLE is not backwards compatible with previous Bluetooth standards.

Dual mode chips combine low energy with the power of classic Bluetooth and to become a defacto feature in new Bluetooth enabled **cellular** phones and **computers**. Dual mode BLE is backwards compatible but targeted to **gateway** products.

EBM-A20 is product from CSR's single mode BLE solution. CSR μ Energy enables ultra low-power connectivity and basic data transfer for applications previously limited by the power consumption, size constraints and complexity of other wireless standards. The CSR μ Energy platform provides everything required to create a Bluetooth low energy product with RF, baseband, MCU, qualified Bluetooth v4.0 stack and customer application running on a single IC.

2. FEATURES

- Bluetooth Low Energy available with CSR1010 QFN
- Bluetooth v4.0 specification
- Single mode Bluetooth low energy
- 7.5dBm Bluetooth low energy maximum TX output power
- -92.5dBm Bluetooth low energy RX sensitivity
- Support for Bluetooth v4.0 specification host stack including:

ATT, GATT, SMP, L2CAP, GAP

- RSSI monitoring for proximity applications
- <600nA ultra low consumption in dormant mode
- Integrated 32kHz and 16MHz crystal or system clock
- Switch-mode power supply
- Programmable general purpose PIO controller
- 10-bit ADC
- 11 digital PIOs
- 3 analogue AIOs
- UART
- 512KB EEPROM
- 3 PWM modules
- Wake-up interrupt
- 64KB RAM and 64KB ROM
- Watchdog timer
- Dimensions:
 - EBM-A20A : 11.75 mm x 14.0 mm x 2.5 mm
 - EBM-A20B with printed antenna : 16.0 mm x 14.0 mm x 2.5 mm
 - EBM-A20C with chip antenna : 16.0 mm x 14.0 mm x 2.5 mm
- Storage temperature range: -40°C ~ +85°C
- Operating temperature range: -30°C ~ +85°C
- Manufactured in conformance with RoHS

3. APPLICATIONS

Building an ecosystem using Bluetooth low energy

Bluetooth low energy enables the transfer of simple data sets between compact devices opening up a completely new class of Bluetooth applications such as watches, TV remote controls, medical sensors and fitness trainers.

Bluetooth low energy takes less time to make a connection than conventional Bluetooth wireless technology and can consume approximately 1/20th of the power of Bluetooth Basic Rate. Supports profiles for sensors, watches, HID's and time synchronization.

Typical Bluetooth low energy applications:

- Sports and fitness
- Healthcare
- Home entertainment
- Office and mobile accessories
- Automotive

- Commercial
- Watches
- Human interface devices

3.1 Device Details

3.1.1 Bluetooth Radio

- On-chip balun (50Ω impedance in TX and RX modes)
- No external trimming is required in production
- Bluetooth v4.0 specification compliant

3.1.2 Bluetooth Transmitter

- 7.5dBm RF transmit power with level control from integrated 6-bit DAC over a dynamic range >30dB
- No external power amplifier or TX/RX switch required

3.1.3 Bluetooth Receiver

- -92.5dBm sensitivity
- Integrated channel filters
- Digital demodulator for improved sensitivity and cochannel rejection
- Fast AGC for enhanced dynamic range

3.1.4 Synthesiser

- Fully integrated synthesiser requires no external VCO varactor diode, resonator or loop filter

3.1.5 Baseband and Software

- Hardware MAC for all packet types enables packet handling without the need to involve the MCU

3.1.6 Physical Interfaces

- SPI master interface
- SPI programming and debug interface
- I²C
- Digital PIOs
- Analogue AIOs

3.1.7 Auxiliary Features

- Battery monitor
- Power management features include software shutdown and hardware wake-up
- Run in low power modes from an external 32.768kHz clock signal

- Integrated switch-mode power supply
- Linear regulator (internal use only)
- Power-on-reset cell detects low supply voltage

3.1.8 Bluetooth Stack

- Support for Bluetooth v4.0 specification features:
 - Master and slave operation
 - Including encryption
- Software stack in firmware includes:
 - GAP
 - L2CAP
 - Security manager
 - Attribute protocol
 - Attribute profile
 - Bluetooth low energy profile support

4. ELECTRICAL CHARACTERISTICS

4.1 Absolute Maximum Ratings

Rating	Min	Max	Unit
Storage temperature	-40	+85	°C

4.2 Recommended Operating Conditions

Operating Condition	Min	Typ	Max	Unit
Operating temperature range	-30	-	85	°C

4.3 Input/Output Terminal Characteristics

4.3.1 Digital Terminals

Input Voltage Levels	Min	Typ	Max	Unit
VIL input logic level low	-0.4	-	0.4	V
VIH input logic level high	0.7 x VDD	-	VDD+0.4	V
Tr/Tf	-	-	25	ns

Output Voltage Levels	Min	Typ	Max	Unit
VOL output logic level low, IOL = 4.0mA	-	-	0.4	V
VOH output logic level high, IOH = -4.0mA	0.75 x VDD	-	-	V
Tr/Tf	1.2	-	5	ns

Input and Tristate Currents	Min	Typ	Max	Unit
With strong pull-up	-150	-40	-10	µA
I ² C with strong pull-up	-250	-	-	µA
With strong pull-down	10	40	150	µA
With weak pull-up	-5.0	-1.0	-0.33	µA
With weak pull-down	0.33	1.0	5.0	µA
CI input capacitance	1.0	-	5.0	pF

4.3.2 AIO

Input Voltage Levels	Min	Typ	Max	Unit
Input voltage	0	-	1.3	V

5. CURRENT CONSUMPTION

Mode	Description	Total Typical Current at 3V
Dormant	All functions are shutdown. To wake up toggle the WAKE pin.	<600nA
Hibernate	VDD_PADS = ON, REFCLK = OFF, SLEEPCLK = ON, VDD_BAT = ON	<1.5μA
Deep sleep	VDD_PADS = ON, REFCLK = OFF, SLEEPCLK = ON, VDD_BAT = ON, RAM = ON, digital circuits = ON, SMPS = ON (low-power mode), 1ms wake-up time	<5μA
Idle	VDD_PADS = ON, REFCLK = ON, SLEEPCLK = ON, VDD_BAT = ON, RAM = ON, digital circuits = ON, MCU = IDLE, <1μs wake-up time	-1mA
RX / TX active	-	~16mA @ 3V peak current

6. SERIAL INTERFACES

6.1 Application Interface

6.1.1 UART Interface

EBM-A20 provides a simple mechanism for communicating with other serial devices using the RS232 protocol. 2 signals implement the UART function, UART_TX and UART_RX. When EBM-A20 is connected to another digital device, UART_RX and UART_TX transfer data between the 2 devices.

UART configuration parameters, e.g. baud rate and data format, are set using EBM-A20 firmware. When selected in firmware PIO[0] is assigned to a UART_TX output and PIO[1] is assigned to a UART_RX input. The UART CTS and RTS signals can be assigned to any PIO pin by the on-chip firmware.

Note: To communicate with the UART at its maximum data rate using a standard PC, the PC requires an accelerated serial port adapter card.

Parameter		Possible Values
Baud rate	Minimum	1200 baud ($\leq 2\%$ Error)
		9600 baud ($\leq 1\%$ Error)
	Maximum	2Mbaud ($\leq 1\%$ Error)
Flow control		CTS / RTS
Parity		None, Odd or Even
Number of stop bits		1 or 2
Bits per byte		8

Table 6.1: Possible UART Settings

6.1.1.1 UART Configuration While in Deep Sleep

The maximum baud rate is 9600 baud during deep sleep.

6.2 SPI Master Interface

The SPI master memory interface in the module is overlaid to uses a further 3 PIOs for the extra pins.

SPI Interface	Pin
Flash_VDD	PIO[2]
SF_DIN	PIO[3]
SF_CS#	PIO[4]
SF_CLK	I2C_SCL
SF_DOUT	I2C_SDA

Table 6.2: SPI Master Serial Flash Memory Interface

7. BLOCK DIAGRAM

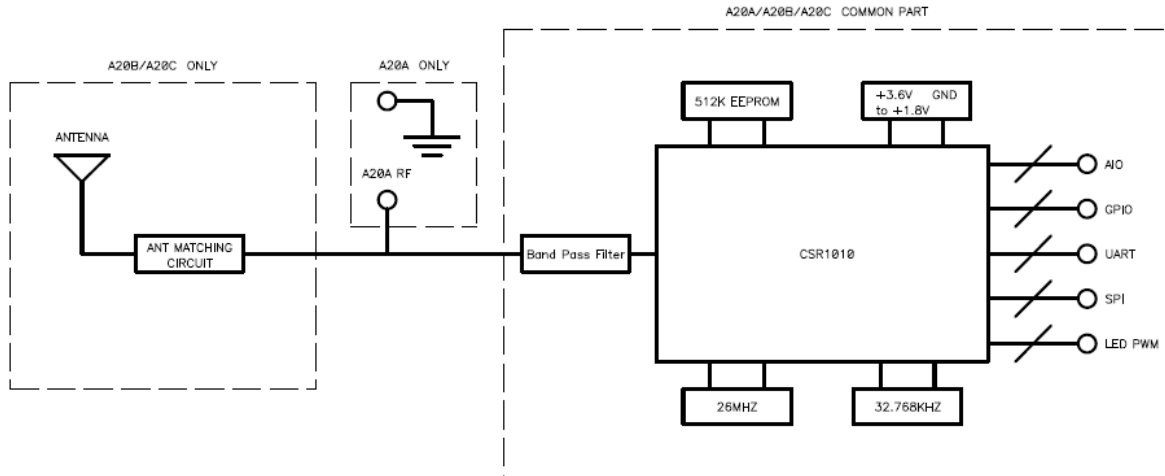

8. PIN DESCRIPTION

8.1 Pin Numbering

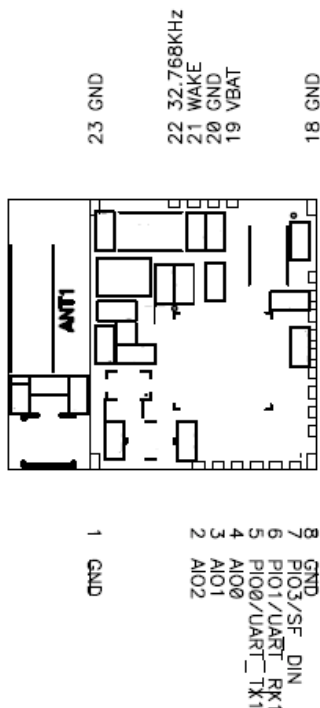

Figure 8.1 EBM-A20C Pin Numbering

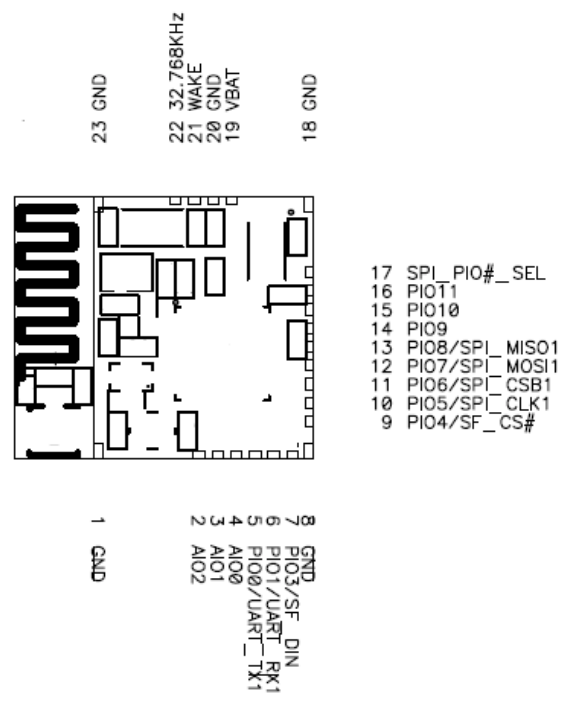

Figure 8.2 EBM-A20B Pin Numbering

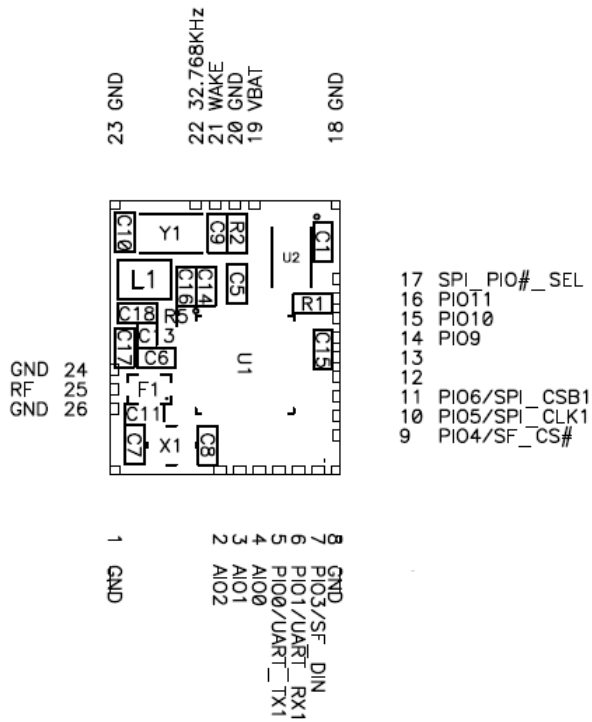

Figure 8.3 EBM-A20A Pin Numbering

8.2 Pin Definition

PIN Name	No	Description
GND	1	Ground
AIO2	2	Analogue programmable I/O line.
AIO1	3	Analogue programmable I/O line.
AIO0	4	Analogue programmable I/O line.
PIO0 UART_TX1	5	Programmable I/O line or UART TX.
PIO1 UART_RX1	6	Programmable I/O line or UART RX.
PIO3 SF_DIN	7	Programmable I/O line or SPI serial flash data (SF_DIN) input.
GND	8	Ground
PIO4 SF_CS#	9	Programmable I/O line or SPI serial flash chip select (SF_CS#).
PIO5 SPI_CLK1	10	Programmable I/O line or debug SPI CLK selected by SPI_PIO#.
PIO6 SPI_CSB1	11	Programmable I/O line or debug SPI chip select (CS#) selected by SPI_PIO#.
PIO7 SPI_MOSI1	12	Programmable I/O line or debug SPI MOSI selected by SPI_PIO#.
PIO8 SPI_MISO1	13	Programmable I/O line or debug SPI MISO
PIO9	14	Programmable I/O line.
PIO10	15	Programmable I/O line.

PIO11	16	Programmable I/O line.
SPI_PIO#_SEL	17	Selects SPI debug on PIO(3.3V SPI mode, 0V PIO mode 10~13) .
GND	18	Ground
VBAT	19	Battery input and regulator enable (active
GND	20	Ground
WAKE	21	Input to wake from hibernate.
32.768KHz_IN	22	Crystal
GND	23	Ground
GND	24	Ground(for EBM-A20A only)
RF	25	Bluetooth transmitter/receiver(for EBM-A20A only)
GND	26	Ground(for EBM-A20A only)

9. MECHANICAL CHARACTERISTICS

9.1 Dimensions

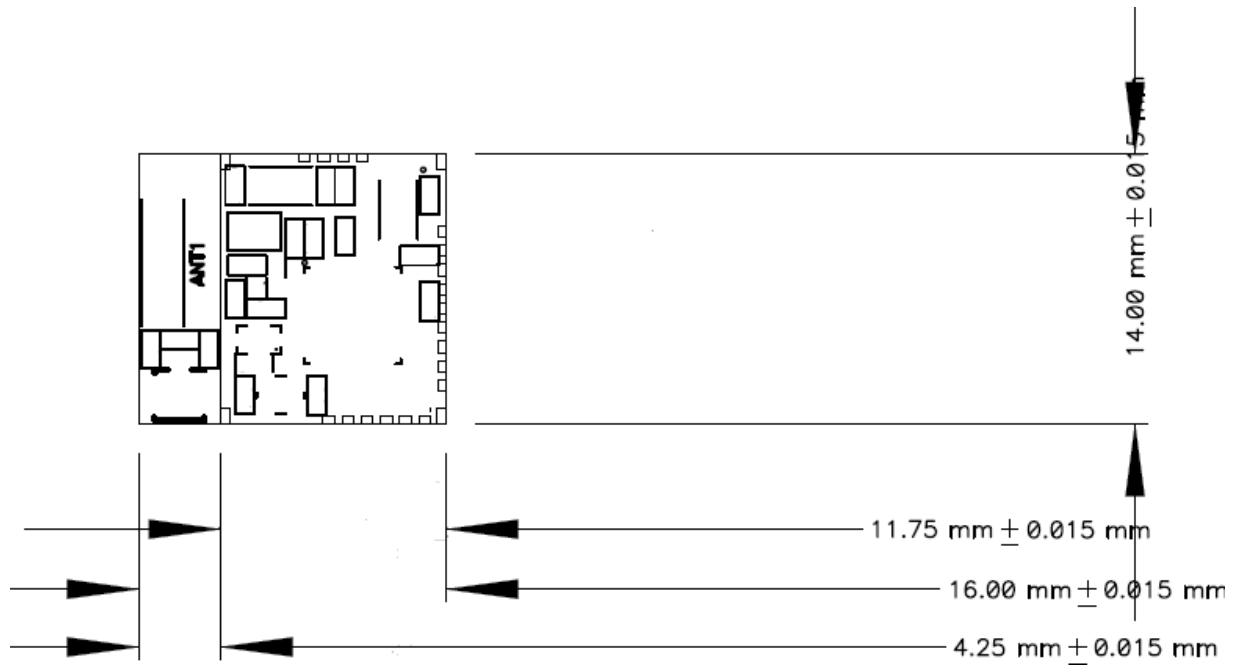

Figure 9.1 EBM-A20C dimension

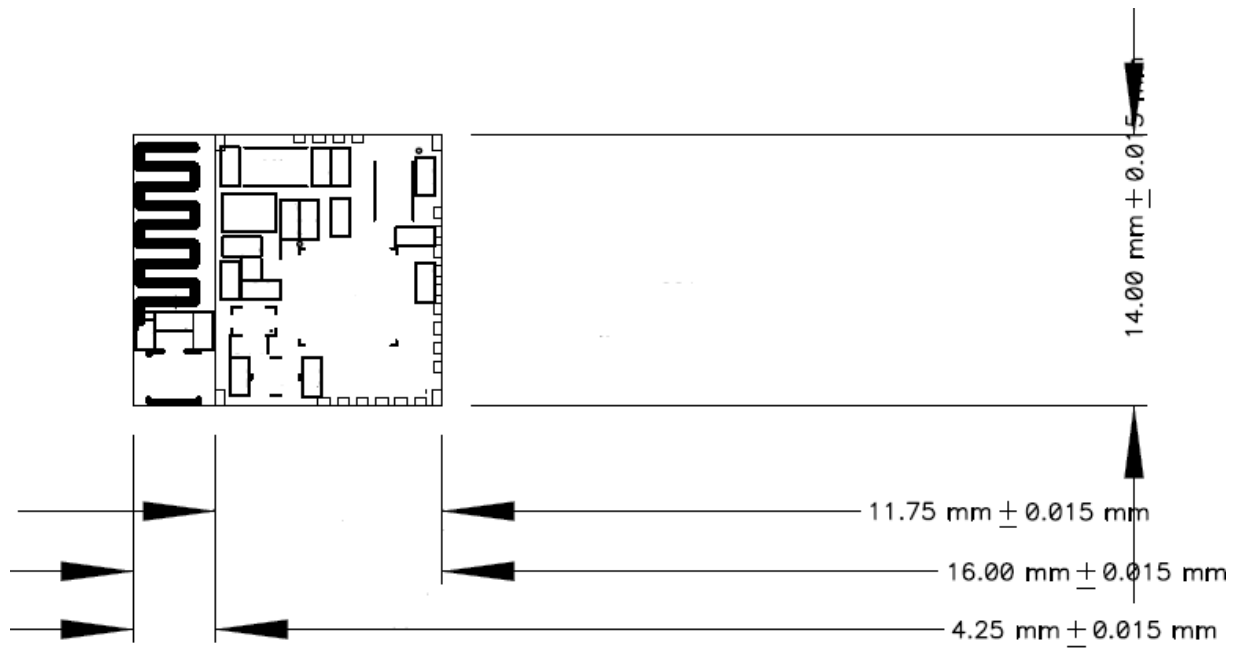

Figure 9.2 EBM-A20B dimension

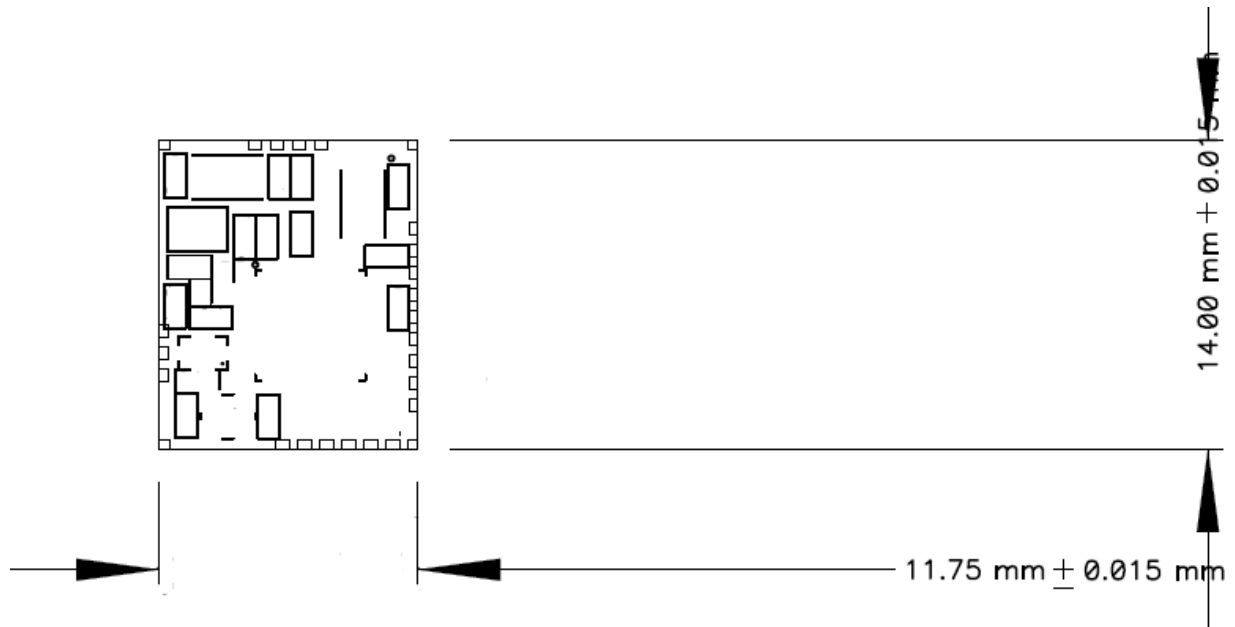

Figure 9.3 EBM-A20A dimension

9.2 Recommended Land Pattern

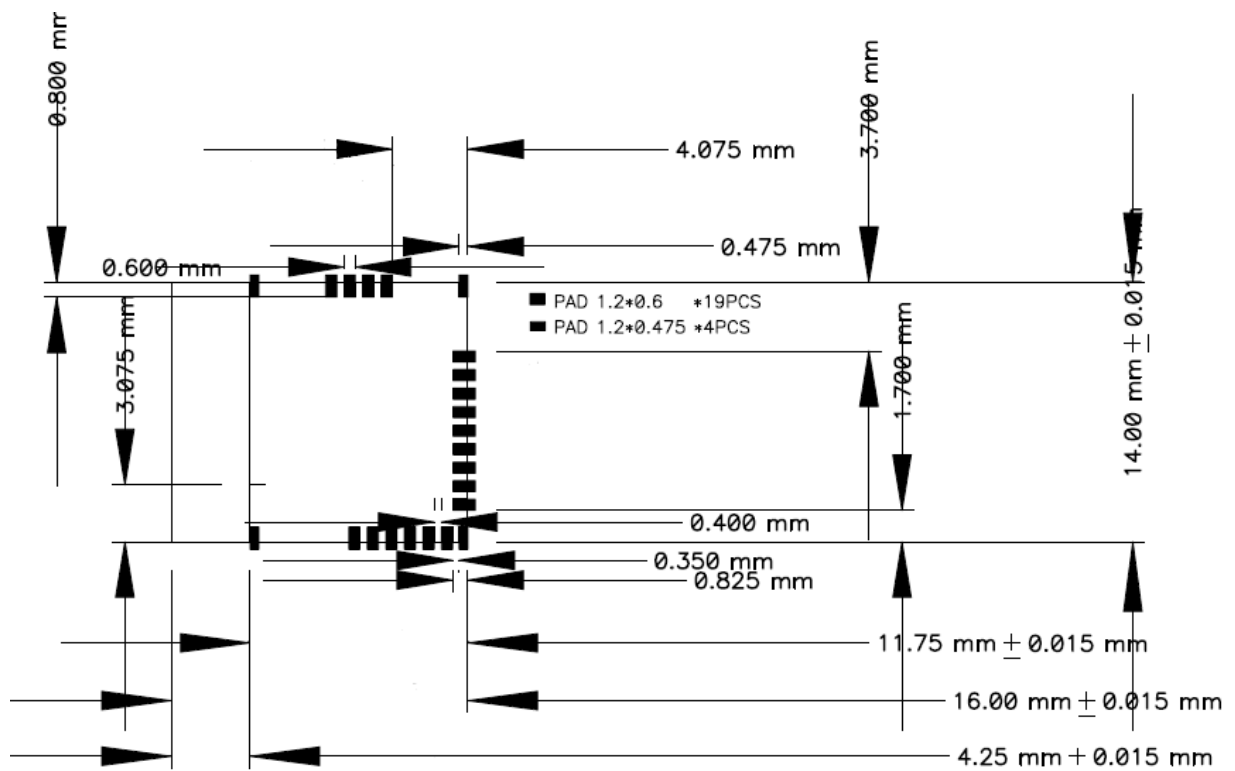

Figure 9.4 EBM-A20B and EBM-A20C land pattern

9.5 Antenna Issues

EBM-A20 is shipped with 3 different antenna designs: EBM-A20C comprises a ceramic antenna which as a component is soldered to the circuit board. This is functional for a EBM-A20B or C integrated into a plastic housing. No additional antenna is required.

For an external antenna to be set in, e.g. because the EBM-A20 is integrated into a metal housing, the ceramic antenna is replaced.

EBM-A20A routes the antenna signal to pin 25. The gain of the external antenna shall not exceed +2dBi.

When using an external Antenna the antenna is fixed and cannot be removed or replaced by the end user. The performance of the internal antenna respectively the external antenna has in any case to be checked within the final integration environment. Adjacent PCBs, components, cables, housings etc. could otherwise influence the radiation pattern or be influenced by the radio wave energy.

It must be ensured that the antenna is not co-located or operating in conjunction with any other antennas, transmitters, cables or connectors. When the internal ceramic antenna is used, certain restrictions are to be considered.

9.6 Application schematic

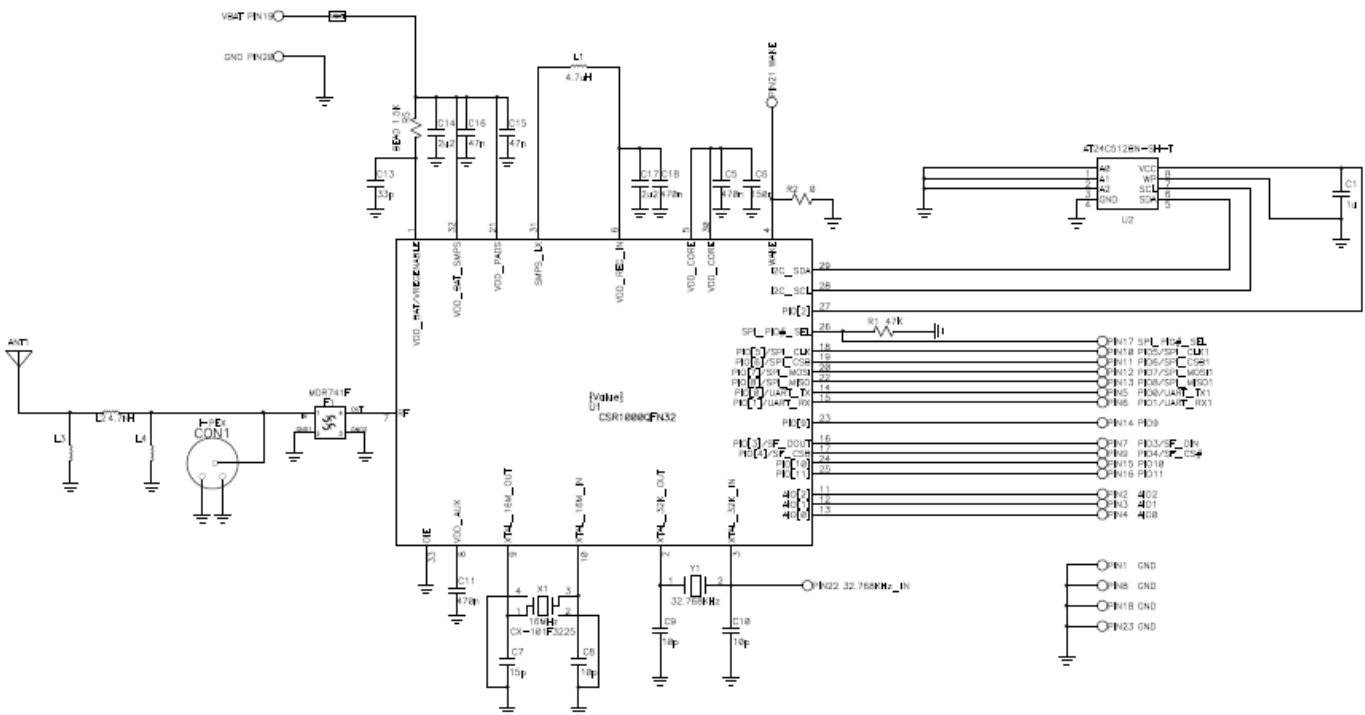

10. APPROVALS/CERTIFICATIONS

The EBM-A20A or B or C has been tested to comply to the appropriate EU, FCC and IC directives. CE testing is intended for end products only. Therefore CE testing is not mandatory for a Bluetooth Module sold to OEM's. However EGIGA TECHNOLOGIES CO LTD provides CE tested modules for customers in order to ease CE compliance assessment of end products and to minimize test effort.

10.1 Declaration of Conformity CE

The EBM-A20A or B or C fully complies with the essential requirements of the following EU directives:

R&TTE 1999/5/EC (Variant /C for external antenna with less than +2dBi gain)

RoHS 2011/65/EC

10.2 FCC Compliance

The EBM-A20B or C has been tested to fulfill the FCC requirements. Test reports are available on request. Grants of the Full Modular Approval will be shown below.

EBM-A20A only:

For selling products implementing the EBM-A20A in the USA you'll have to apply for a Class II Permissive Change from the FCC authorities. Depending on antenna gain and other factors the FCC TCB will issue a reduced test plan for re-testing. SPK can assist customers with conducting this procedure on request. Especially the test plan reduction and cost optimization may be items worth to look at.

10.2.1 FCC Grant

10.2.2 FCC Statement

This device complies with 47 CFR Part 2 and Part 15 of the FCC Rules and with. Operation is subject to the following two conditions:

- (1) this device may not cause harmful interference, and
- (2) this device must accept any interference received, including interference that may cause undesired operation.

10.2.3 FCC Caution

Warning: Changes or modifications made to this equipment not expressly approved by EGIGA TECHNOLOGIES CO LTD may void the FCC authorization to operate this equipment.

10.2.4 FCC Warning

You are cautioned that changes or modifications not expressly approved by the part responsible for compliance could void the user's authority to operate the equipment.

This equipment has been tested and found to comply with the limits for a Class B digital device, pursuant to Part 15 of the FCC Rules. These limits are designed to provide reasonable protection against harmful interference in a residential installation. This equipment generates, uses and can radiate radio frequency energy and, if not installed and used in accordance with the instructions, may cause harmful interference to radio communications. However, there is no guarantee that interference will not occur in a particular installation. If this equipment does cause harmful interference to radio or television reception, which can be determined by turning the equipment off and on, the user is encouraged to try to correct the interference by one or more of the following measures:

- Reorient or relocate the receiving antenna.
- Increase the separation between the equipment and receiver.
- Connect the equipment into an outlet on a circuit different from that to which the receiver is connected.
- Consult the dealer or an experienced radio/TV technician for help.

10.2.5 FCC RF Radiation Exposure Statement

The EBM-A20B or C complies with the FCC/ radiation exposure limits set forth for an uncontrolled environment. End users must follow the specific operating instructions for satisfying RF exposure compliance. This transmitter must not be co-located or operating in conjunction with any other antenna or transmitter.

The output power is $< 10\text{mW EIRP}$ and therefore according to "FCC KDB 447498 D01 General RF Exposure Guidance v05" Appendix A, table "SAR Exclusion Threshold", excluded from SAR testing for test separation distances $\geq 5\text{mm}$ and if it is not used in co-locations with other antennas. If the product implementing the EBM-A20B or C has other antennas in co-location or separation distances $< 5\text{mm}$ an FCC TCB should be asked for a Class II Permissive Change.

RF exposure evaluation of devices implementing the EBM-A20A should be done with the collaboration of the FCC TCB working on the Class II Permissive Change Request.

10.2.6 FCC Labeling Requirements for the End Product

Any end product integrating the Model: EBM-A20A or B or C must be labeled with at least the following information:

This device contains transmitter with

FCC ID: **2ABQH-eGMA20**

10.3 IC Compliance

The EBM-A20A has been tested to fulfill the IC requirements. Test reports RSS-210 of Industry Canada are available on request. Grants of the Full Modular Approval will be shown below.

For selling products implementing the EBM-A20B or C in Canada you'll have to apply for a Class II Permissive Change from the IC authorities. Depending on antenna gain and other factors the IC TCB will issue a reduced test plan for re-testing. SPK can assist customers with conducting this procedure on request. Especially the test plan reduction and cost optimization may be items worth to look at.

10.3.1 IC Grant

10.3.2 IC Statement

This device complies with Industry Canada license-exempt RSS standard(s). Operation is subject to the following two conditions:

- (1) this device may not cause interference, and
- (2) this device must accept any interference, including interference that may cause undesired operation of the device.

Cet appareil numérique de est conforme aux normes canadiennes licence-exempt RSS standard(s).

Son fonctionnement est soumis aux deux conditions suivantes :

- (1) cet appareil ne doit pas causer d'interference et
- (2) cet appareil doit accepter toute interference, notamment les interferences qui peuvent affecter son fonctionnement.

10.3.3 IC Caution

Warning: Changes or modifications made to this equipment not expressly approved by EGIGA TECHNOLOGIES CO LTD may void the IC authorization to operate this equipment.

10.3.4 IC RF-exposure Statement

This equipment is portable device. The output power of this device is less than 20mW. The SAR test is not required.

RF exposure evaluation of devices implementing the EBM-A20A should be done with the collaboration of the IC TCB working on the Class II Permissive Change

Request.

10.3.5 IC Labeling Requirements for the End Product

Any end product integrating the Model: EBM-A20A or B or C must be labeled with at least the following information:

This device contains transmitter with

IC-ID: **11696A-eGMA20**

10.3.6 IC Label Information

The EBM-A20 shows IC-ID on the product label. IC allows to state the IC-ID in the product manual. This product has been granted to do so.

Model: EBM-A20A or B or C

The IC-ID is: **11696A-eGMA20**

10.4 TELEC Compliance

10.5 Bluetooth Qualification

The EBM-A20 is a qualified design according to the Bluetooth Qualification Program Reference Document (PRD) V2.1 The Qualified Design ID (QDID) is:

B022156

According to the Bluetooth SIG rules (Qualification Program Reference Document – PRD V2.1) you are required to perform the mandatory End Product Listing (EPL) for your product.



QDL Bluetooth® Qualified Design Listing

The Bluetooth SIG Hereby Recognizes

EGIGA TECHNOLOGIES CO LTD

Member Company

Bluetooth 4.0 LE single mode module

Qualified Design Name

Qualified Design ID(s): **B022156**

Specification Name: **4.0**

Product Type: **Controller Subsystem**

Model Number: **eGM-A20(A/B/C)**

BQE Name: **Ricky Chen**

Listing Date: **23 January 2014**

Assessment Date: **23 January 2014**

Hardware Version Number: **Rev.1.0.2**

Software Version Number: **0.92**

This certificate acknowledges the *Bluetooth*® Specifications declared by the member were achieved in accordance with the *Bluetooth* Qualification Process as specified within the *Bluetooth* Specifications and as required within the current PRD



10.6 RoHS/SVHC Declaration

The actual version of RoHS Supplier Declaration according to the EU Directive 2011/65/EC.

11. PACKAGE

Tray Type

- a. Carrier not be exceed 1mm in 100mm.
- b. Packing dimensions meet : 390mm * 270mm * 15mm
- c. Material : white anti-static polystyrene
- d. Component load per tray : 100pcs

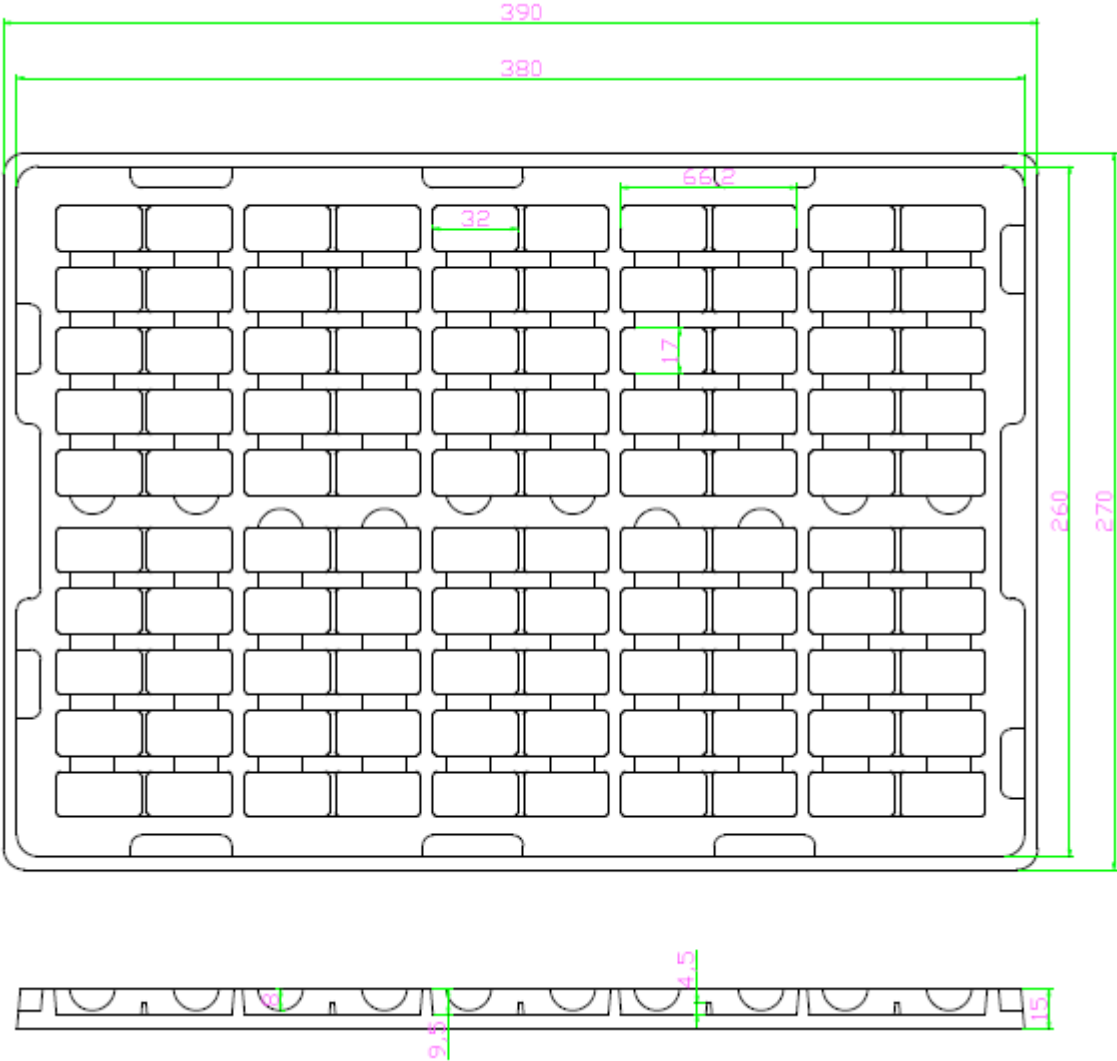

SPK Bluetooth module design data