

GSM850/GSM900/DCS1800/DCS1900 Helical Antenna

1. Explanation of Title:

W T H 4 3 0 0 5

(1) (2) (3) (4) (5)

(1) System code :

(2) Area code :

(3) Product type :

(4) Customer code :

(5) Suffix :

2. Summary

This report is to account for the measurement setup and results of Quad-Band. The measurement setup includes reflection coefficient, pattern, and gain measurements.

2-1 Frequency Band

DRAWING : Monte	DESIGNED BY : David	CHECKED BY : Nick	APPROVED BY : D.S.M
UNLESS OTHER SPECIFIED TOLERANCES ON :		TITLE:	WTH43005
X =	X.X =	X.XX =	Part No. 112040005
REV. : B1	UNIT : mm	Document No.	112040005

Frequency	T_x (MHz)	R_x (MHz)
GSM/850E	824~849	870~894
GSM	880 ~ 915	925 ~ 960
DCS	1710 ~ 1785	1805 ~ 1880
PCS	1850~1909	1930~1990

3. Measurement setup:

(1) Reflection Coefficient Measurement:

(a) Instrument: Network Analyzer

(b) Setup:

(I) Calibrate the Network Analyzer by one port calibration using O.S.L. calibration kits.

(II) Connect the antenna under test to the Network Analyzer.

(III) Measure the S11 (reflection coefficient) shown in Fig.1.

(IV) Generally, the S11 is less than -10dB to ensure the 90% power into antenna and only less than 10% power back to system.

DRAWING : Monte	DESIGNED BY : David	CHECKED BY : Nick	APPROVED BY : D.S.M
UNLESS OTHER SPECIFIED TOLERANCES ON :		TITLE:	WTH43005
X =	X.X =	Part No.	112040005
REV. : B1	UNIT : mm	Document No.	112040005

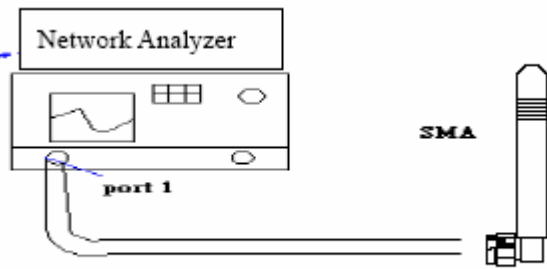

Fig.1

(2) Pattern measurement:

a. The WAVEFAR'S anechoic chamber is a far-field measurement system with size of 7m×3.3m×3.3m. The quiet zone region is 30cm×30cm×30cm in the center of the rotator.

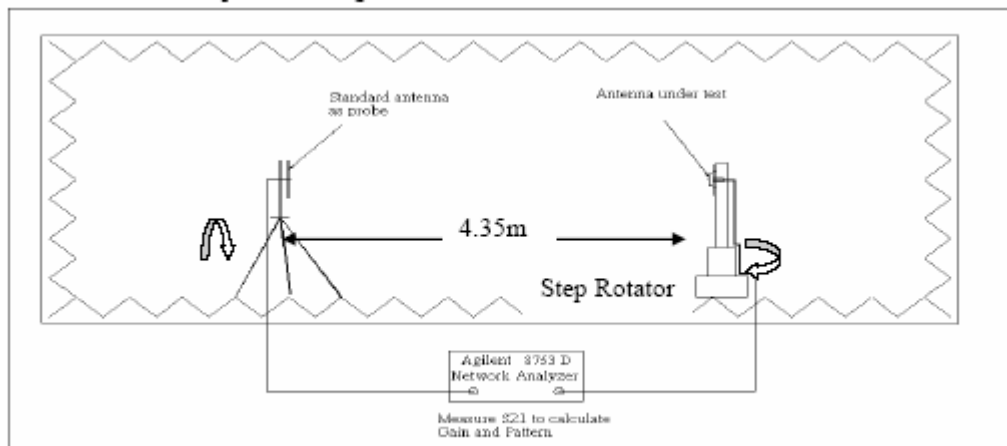

Fig.2 The interior components of the anechoic chamber

b. The probing antenna is the BBHA 9120 LFA 700MHz ~ 6GHz module (9120D horn antenna), which is placed in the one side of the chamber room. And the antenna under testing (AUT) is placed in the other side of the chamber. The distance between the probing antenna and the AUT is about 4m.

c. While we measure the radiation patterns by rotating AUT with 360 degrees and repeat again by replacing the AUT with the standard gain antenna under test, we compare both data and using a formula to obtain the gain of AUT. The standard gain antenna is a gain horn (BBHA 9120 LFA 700MHz ~ 6GHz).

DRAWING : Monte	DESIGNED BY : David	CHECKED BY : Nick	APPROVED BY : D.S.M
UNLESS OTHER SPECIFIED TOLERANCES ON :		TITLE:	WTH43005
X =	X.X =	Part No.	112040005
REV. : B1	UNIT : mm	Document No.	112040005

$$G_{AUT} = G_{stand} + P_{AUT} - P_{stand}$$

G_{AUT} : Gain of AUT

G_{stand} : Gain of Standard Gain Antenna

P_{AUT} : Measured Power of AUT

P_{stand} : Measured Power of Standard Gain Antenna

- d. The scanning method is CW wave with 6 degree by one step.
- e. We measure the radiation pattern in the free space situation at the lowest, middle and highest frequency for the H(X-Y), E1(Y-Z) planes, which defined in figure next page.

(3) Plane definition:

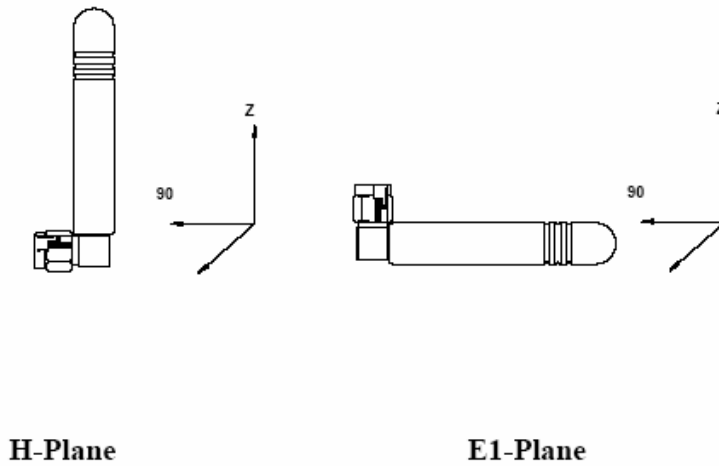
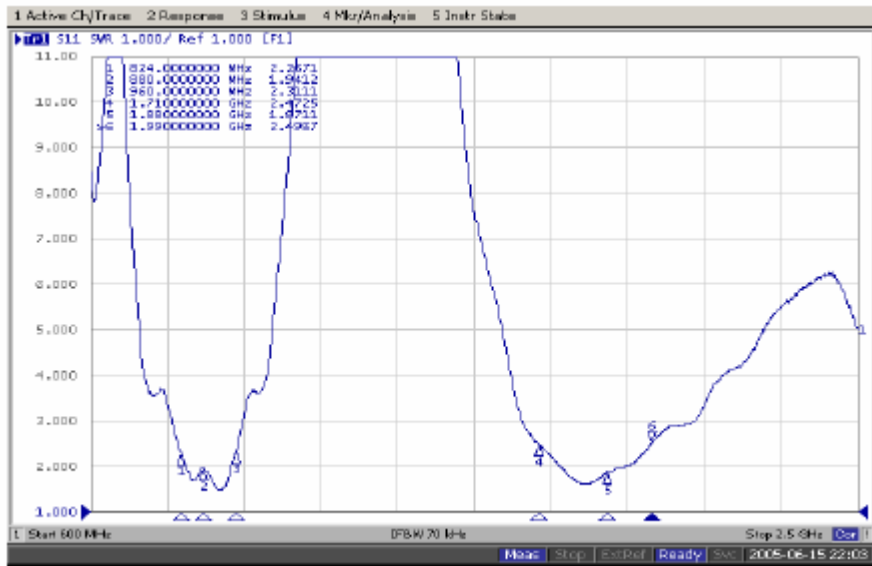

Fig.3 The plane definition for H and E1 planes.

DRAWING : Monte	DESIGNED BY : David	CHECKED BY : Nick	APPROVED BY : D.S.M
UNLESS OTHER SPECIFIED TOLERANCES ON :		TITLE:	WTH43005
X =	X.X =	Part No.	112040005
REV. : B1	UNIT : mm	Document No.	112040005

4. V.S.W.R and Return Loss:

4-1 V.S.W.R value



4-2 Return Loss value

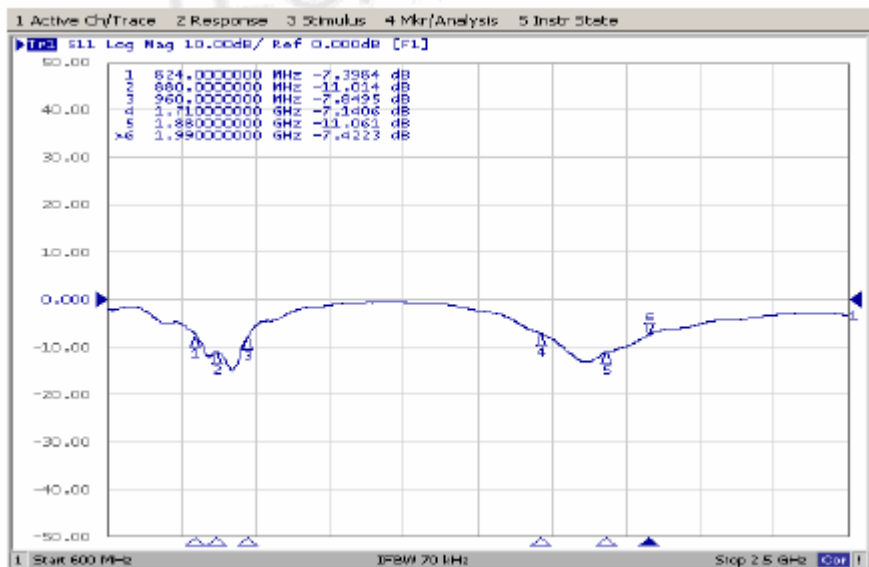

DRAWING : Monte	DESIGNED BY : David	CHECKED BY : Nick	APPROVED BY : D.S.M
UNLESS OTHER SPECIFIED TOLERANCES ON :		TITLE:	WTH43005
X =	X.X =	Part No.	112040005
REV. : B1	UNIT : mm	Document No.	112040005

	Frequency (MHz)				
VSWR	824MHz	960MHz	1710MHz	1880MHz	1990MHz
Value	≤3.0	≤3.0	≤3.0	≤3.0	≤3.0

5. Gain and Radiation pattern:

5-1 Antenna Gain

Frequency (MHz)	H Plane			E1 Plane			
	Unit dBi	Max.	Min.	Avg.	Max.	Min.	Avg.
824		1.52	-5.61	-1.64	-0.45	-10.65	-4.09
880		-0.60	-9.54	-2.94	-1.88	-12.53	-4.42
960		-0.42	-4.52	-2.06	-1.36	-10.19	-4.47
1710		-1.89	-10.09	-3.62	-0.65	-13.31	-3.39
1800		0.79	-9.60	-2.60	1.20	-13.02	-2.30
1880		1.16	-10.93	-2.54	1.03	-11.55	-2.98
1990		1.57	-18.53	-1.21	1.44	-15.88	-2.22

DRAWING : Monte	DESIGNED BY : David	CHECKED BY : Nick	APPROVED BY : D.S.M
UNLESS OTHER SPECIFIED TOLERANCES ON :		TITLE:	WTH43005
X =	X.X =	X.XX =	Part No. 112040005
REV. : B1	UNIT : mm	Document No.	112040005

5-2 Radiation Patterns

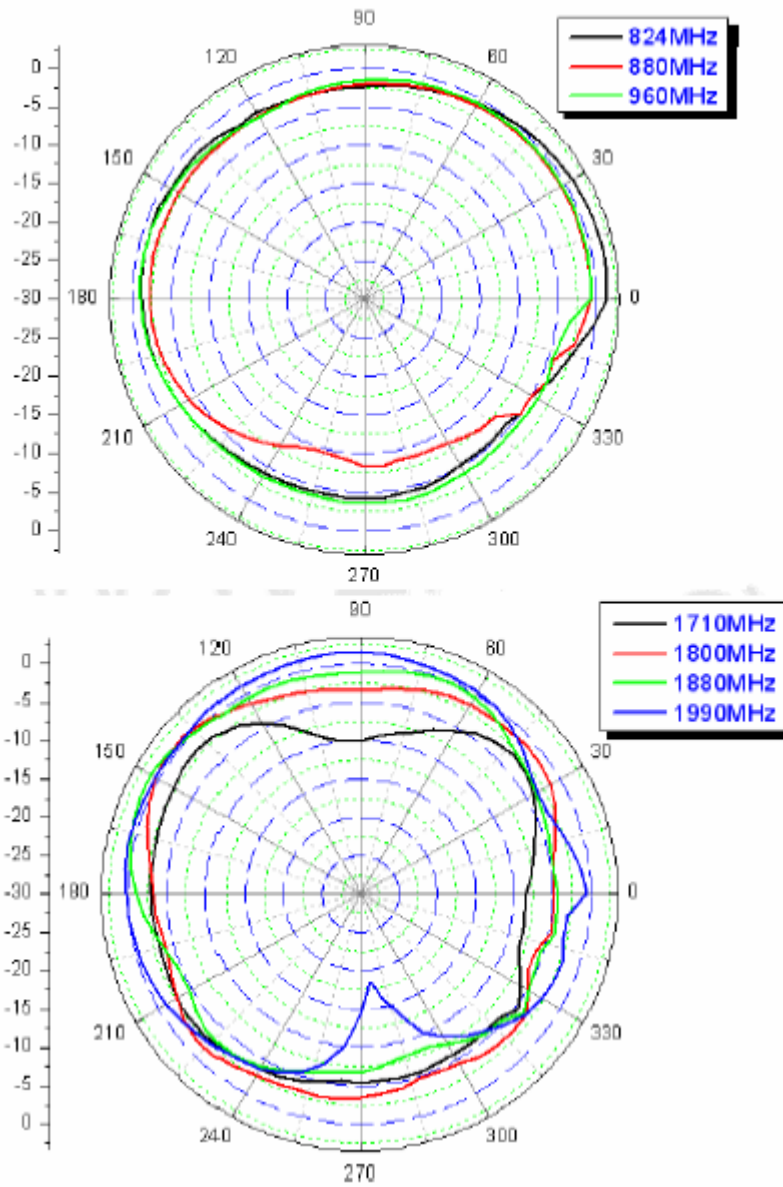

H-plane

DRAWING : Monte	DESIGNED BY : David	CHECKED BY : Nick	APPROVED BY : D.S.M
UNLESS OTHER SPECIFIED TOLERANCES ON :		TITLE:	WTH43005
X =	X.X =	Part No.	112040005
REV. : B1	UNIT : mm	Document No.	112040005

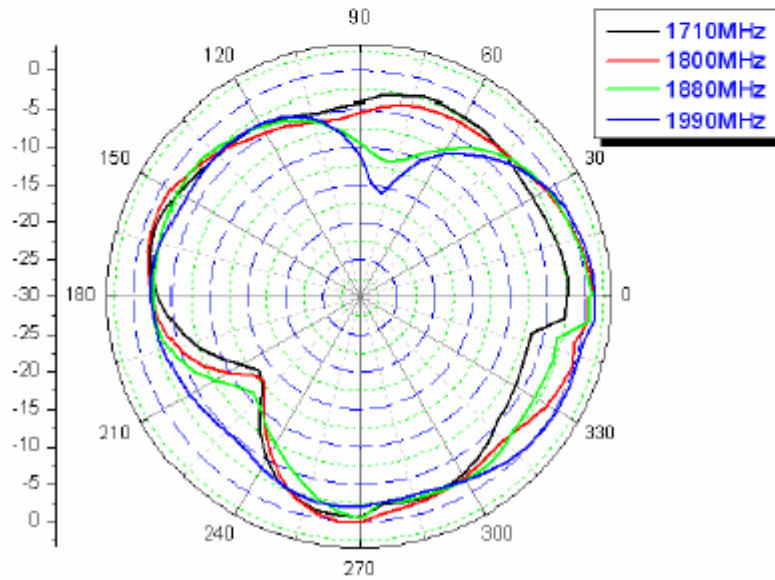
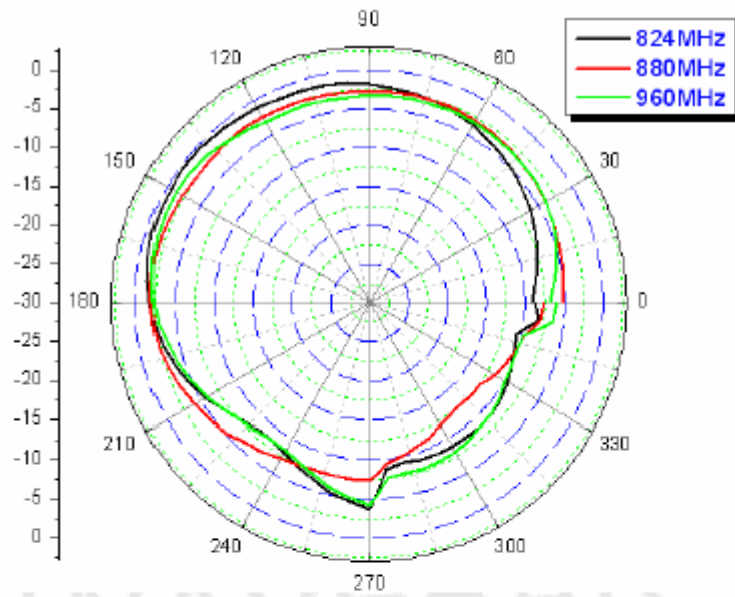

E1-plane

DRAWING : Monte	DESIGNED BY : David	CHECKED BY : Nick	APPROVED BY : D.S.M
UNLESS OTHER SPECIFIED TOLERANCES ON :		TITLE:	WTH43005
X =	X.X =	Part No.	112040005
REV. : B1	UNIT : mm	Document No.	112040005

6. Mechanical Specification:

6-1 Mechanical Configuration:

The appearance of the antenna is according to drawing Figure 6-1.

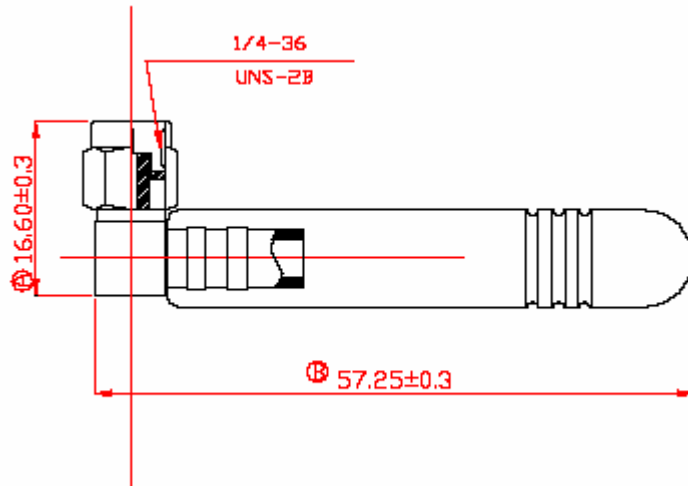

Figure 6.1 antenna drawing

DRAWING : Monte	DESIGNED BY : David	CHECKED BY : Nick	APPROVED BY : D.S.M
UNLESS OTHER SPECIFIED TOLERANCES ON :		TITLE:	WTH43005
X =	X.X =	Part No.	112040005
REV. : B1	UNIT : mm	Document No.	112040005