

CIRCUIT DIACRAM

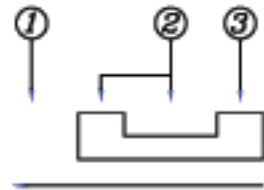

P.C.B LAND PATTERN

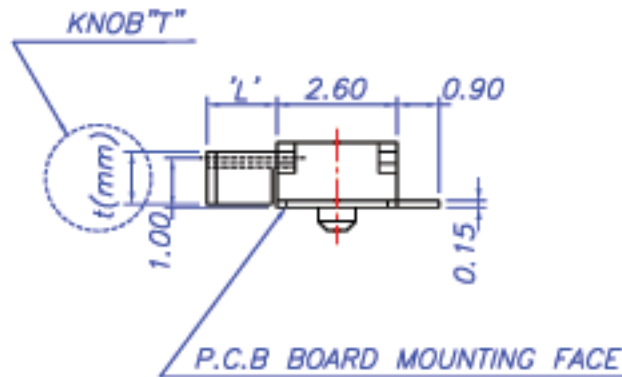
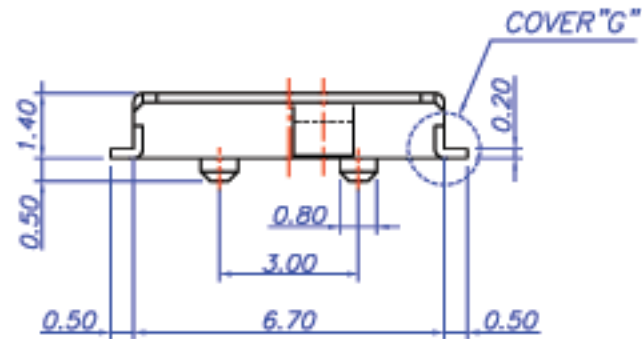
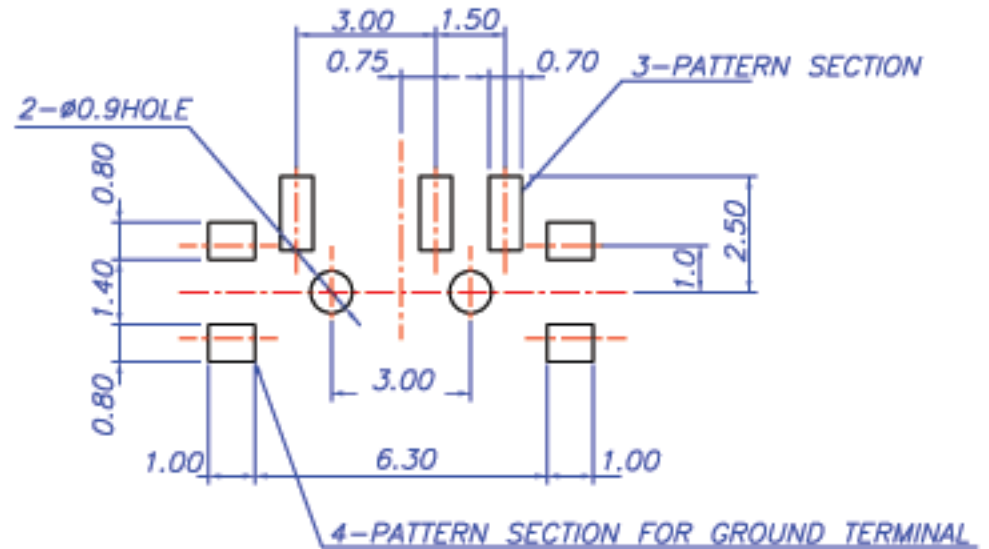

SPECIFICATION

1. RATING: 0.3A 4V DC
2. CONTACT RESISTANCE: 70mΩ MAX
3. OPERATING FORCE: 150±100gf standard
: 100±100gf special
4. OPERATING LIFE: 10,000 CYCLE
5. GENERAL TOLERANCE: ±0.2m/m
6. PRODUCTS NOT WITH S IN THE DRAWING ARE OF STANDARD TYPE.
7. Knob Thickness : t:1.1mm L:1.5mm PA
t:0.4mm L:1.5mm PB
t:1.1mm L:2.3mm PAL
8. Knob color : W-white
B-Black



單位
mm

比例
6 : 1

日期
10-05-2000

核准

審核

設計繪圖

料號

BSL-1290()-()

頁數

1/1

S.P.K ELECTRONICS CO., LTD. 兆福企業有限公司

TEL: 886-2-23462323 FAX: 886-2-23463939

品名

SLIDE SWITCH

圖號

BSL-1290()-()

版本

A