

S.P.K. Electronics Co., Ltd.

Engineering Specifications

(Sample)

Customer :
Product : Touch Panel (Non Glare)
Model : TR4-035F-09-A
Mode : Four-Wire Analog Resistive Series
Version : E/S 02-01
Date : Sep-11-2006

Confidential

Customer Sample Approval
Date of Signature : _____

Approved	Reviewed	Prepared
陳民偉	江雅琦	汪慈伶

Version	Revision Date	Page	Content
1	Sep-11-2006		First draft

Confidential

TABLE OF CONTENTS

1. FEATURES.....	Page 4
2. DIMENSIONS.....	Page 4
3. ENVIRONMENTAL CHARACTERISTICS.....	Page 5
4. OPTICAL CHARACTERISTICS.....	Page 5
5. ELECTRICAL CHARACTERISITCS.....	Page 5
6. MECHANICAL CHARACTERISTICS.....	Page 6
7. RELIABILITY.....	Page 6
8. DURABILITY.....	Page 6
9. LINEARITY INSPECTION METHOD.....	Page 7
10. APPEARANCE INSPECTIONS.....	Page 8
11. ATTENTION FOR MOUNTING CONDITION.....	Page 9
12. WARRANTY.....	Page 9
13. CAUTIONS.....	Page 10
14. APPENDICES.....	Page 10

1. FEATURES

Type	Four-Wire Analog Resistive Touch Panel		
Structure	Material	Thickness	Type
	ITO/PET	188um	Non-Glare
	ITO/GLASS	1.1mm	Normal
Input Mode	Stylus or Finger		
Connector	FPC		

2. DIMENSIONS

Item	Specification (unit in mm)
(1) Frame Size	84.25±0.30x65.40±0.30
(2) View Area	75.70±0.20x56.06±0.20
(3) Active Area	72.60±0.20x53.16±0.20
(4) Total Thickness	1.35±0.20
(5) Tail Length	40.00±1.00

Confidential

[Engineering Drawing]

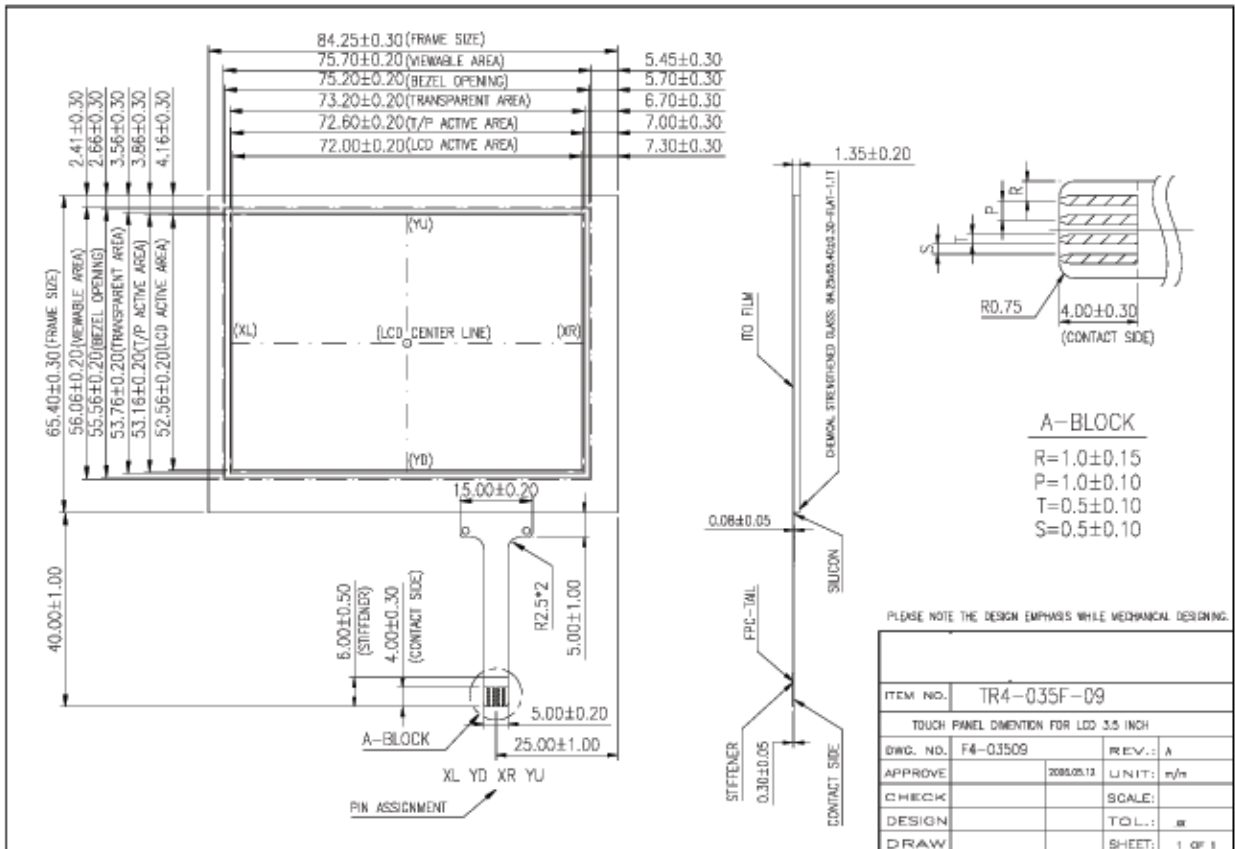

3. ENVIRONMENTAL CHARACTERISTICS

Status		Temperature
(1)	Operation	-20~70
(2)	Storage	-40~80

Note: The environment is of normal atmosphere pressure

4. OPTICAL CHARACTERISTICS

Item		Specification
(1)	Transparency	80±2%

Note1: Transparency is measured by using BYK-Gardner instrument.

Note2: Test method-satisfy (2) of item 10.

5. ELECTRICAL CHARACTERISTICS

Item		Specification
(1)	Terminal Resistance	Up: 400~1200Ω, Down: 100~500Ω
(2)	Linearity	1.5% ,(Test method reference Item 9)
(3)	Operation Voltage	5VDC
(4)	Chattering	30ms
(5)	Insulation	20MΩ, 25VDC
(6)	Endurance	No arcing damage at 25VDC, 60sec.
(7)	Operative Resistance	2KΩ

Confidential

6. MECHANICAL CHARACTERISTICS

	Item	Condition	Specification
(1)	Activation Force	Stylus R0.8	Avg: 5~50g
(2)	Impact	22.0mm Steel Ball/45g Height = 30cm	1 time, no damage (Impact at center area)
(3)	Static Load	15kg at 20mm area for 30 Sec	Satisfy (1), (2), (5) of item 5
(4)	Hardness	3H pencil, pressure 1n/45°(JIS K5400)	3H
(5)	Tail Peeling	800g/cm by 90 degree	Satisfy (1) of item 5
(6)	Tail Bending	10 times by radius R:1mm 500g left & right 135 degree	Satisfy (1) of item 5

7. RELIABILITY

	Item	Condition	Specification
(1)	Constant Temperature / Humidity	60 /90%RH ,240 hrs and normalized for 4 hrs	Satisfy (1) of item 4; (1), (2), (5) of item
(2)	Heat Cycle	80 /240 hrs and normalized for 4 hrs	Same as above
(3)	Cold Cycle	-40 /240 hrs and normalized for 4 hrs	Same as above
(4)	Thermal Cycle	-40~80 (0.5hr each), 10 Cycles (within 24 hr) and normalized for 4 hrs	Same as above

8. DURABILITY

	Item	Condition	Specification
(1)	Finger Touch	1,000,000 times, R8, Silicon Rubber (Please refer to Appendix II)	Satisfy(1),(2),(5) of item 5
(2)	Pen Sliding	100,000 times, R0.8, Stylus (Please refer to Appendix II.)	Satisfy(1),(2),(5) of item 5

**9. LINEARITY
INSPECTION
METHOD**

Voltage (DC 5V) is applied to X1 or Y2 and ground (0V) is applied to X2 or Y1.

Use stylus to draw straight lines (LX and LY) at 5 mm intervals within active area and detect the voltage at Y2 or X1.

Measure the voltage differences between X1 and X2 or Y1 and Y2.

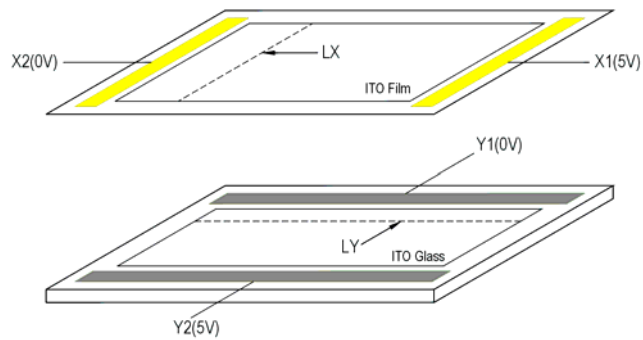

Confidential

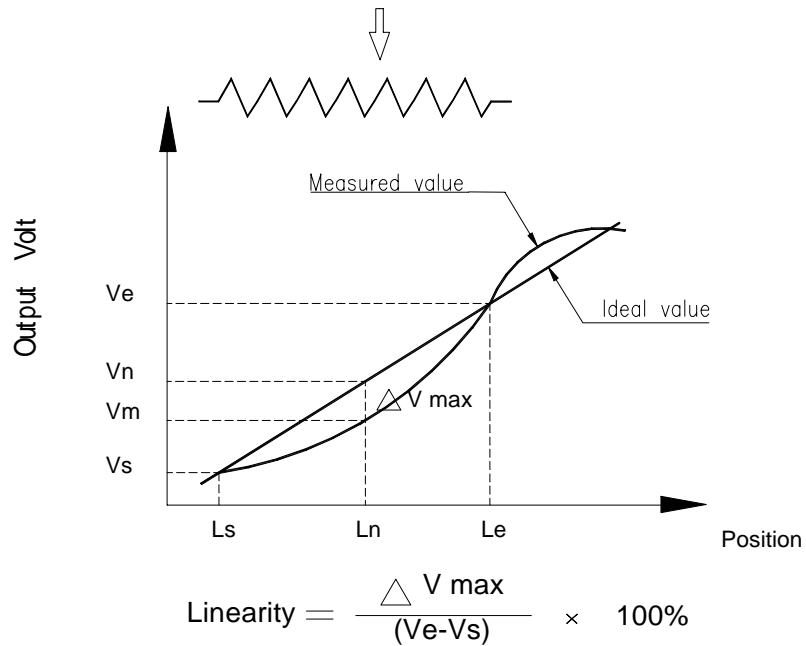

10. APPEARANCE INSPECTIONS

- (1) The flaws and impurities are allowed outside of the viewing area except for those affecting electrical functions.
- (2) The inspection shall be performed by using one 1200±200LUX fluorescent lamp as back or side light. The panel shall be placed at 30cm away from eyes as shown below.

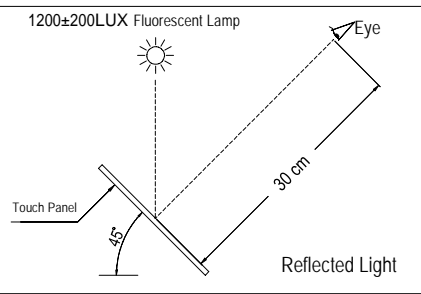
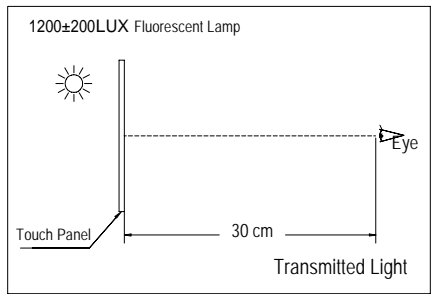

(3) Glass flaw

Confidential

Corner flaw		Please refer to Appendix I
Edge flaw		Please refer to Appendix I
Progressive flaw		Not allowed

T=Glass Thickness

11. ATTENTION FOR MOUNTING CONDITION

- (1) The support which fixes the touch panel must be designed outside of Viewable Area.
- (2) To avoid accidental pressing on the touch panel, enclosure must be designed with enough gap^(a) to panel surface.
- (3) Bezel must not touch^(b) the Viewable Area.
- (4) We recommend elastic material to made support.
- (5) After mounting, avoid direct metal contact with edges^(c) of the panel.

Con

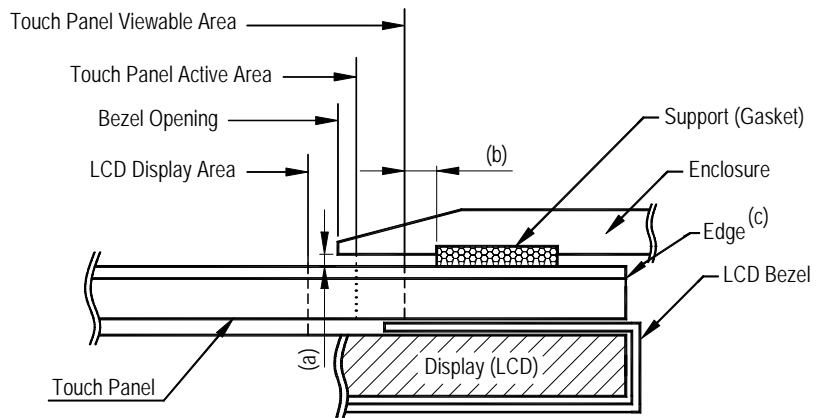

12. WARRANTY

With the exceptions listed below, all SPK's products are guaranteed free of manufacturing defects for a period of up to one year. All defected products will be repaired or exchanged free of charge if determined to be the responsibility of SPK. SPK reserves the sole discretion in determining the causes and the responsibilities of any defects or damages. For details, please refer to SPK's "Product Warrant Policy".

List of Exceptions:

1. Damages caused by improper handling of clients, including and not limited to, during shipping or manufacturing processes.
2. Damages caused by disasters, either by natural causes or human factors, after the delivery of products.
3. Any repairs, modifications or disassembling of SPK's products without prior notification to and the consent of SPK.

13. CAUTIONS

Storage	(1) Store packaged products at the temperature and humidity mentioned in the specifications with care. Do not expose products to direct sunlight or stress such as that caused by piling.
Unpacking	(1) Check for the correct direction of the package before unpacking.
Handling	(1) Clean finger sacks or gloves and mask are required during handling to prevent finger-prints or stain on the products and damages to the products caused by sharp edges. (2) Do not handle the viewing area of the panel. (3) Do not handle the panel at the tail (connector) to prevent detachment of the tail to the panel.
Cleaning	(1) Clean and soft clothes with neutral detergent or with ethanol may be used for cleaning. (2) Do not use any chemical solvent, acidic or alkali solution. (3) Do not allow liquid from soaking into the joint of film and glass that may result in peeling or malfunctioning.
Installing and Assembling	(1) Excessive force or strain to the panel or the tail is prohibited. (2) Provide a clearance of at least 0.3mm between panel and module. (3) The panel is designed with air groove. Insulation and cushioning pads should be designed around the edges of the panel to prevent liquid penetration or dust gathering.
Operating	(1) Operate with a stylus (tip R0.8 or over), or with a finger without applying excessive load. Sharp edged or hard articles are prohibited. (2) The gathering of dew in the panel may occur with abrupt temperature or humidity changes. A stable environment condition is recommended.
Others	(1) Keep the surface clean. No adhesives should be applied. (2) Avoid high voltage and static charge. (3) SPK reserves the right to substitute materials with the same grade and specification.

It is absolutely forbidden to draw lines along with the edge of the housing because the extreme force will damage the upper layer and cause the failure of the touch panel.

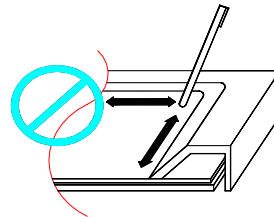

14. APPENDICES

Appendix I	Appearance Specifications
Appendix II	Durability Test Method
Appendix III	Cautions for Product Handling
Appendix IV	Packing Method

[Appendix I]

Appearance Specifications

Defect Name	Criteria	Judgment
Particle	$D \leq 0.2$	OK
	$0.2 < D \leq 0.25$	Total 3, follow Condition 1, OK
	$D > 0.25$	NG
Blur Stain and Interference Pattern	$D \leq 0.2$	OK
	$0.2 < D \leq 0.25$	Total 3, follow Condition 1, OK
	$D > 0.25$	NG
Linear Object	$W \leq 0.05$ and $L \leq 8$	OK
	$0.05 < W \leq 0.1$ and $L \leq 8$	Total 3, follow Condition 1, OK
	$W > 0.1$ and $L > 8$	NG
Scratch	$W \leq 0.05$ and $L \leq 8$	Total 3, follow Condition 1, OK
	$0.05 < W \leq 0.1$ and $L \leq 8$	Total 1, OK
	$W > 0.1$ or $L > 8$	NG
Damage to Glass A: corner flaw B: Edge flaw	$X \leq 2, Y \leq 2, Z \leq \frac{1}{3}T$ Please refer to the figures in page 8	Total 2, OK Damages with possible worsening are not allowed
<p>Condition 1: Distance between defects should not be less than 20mm.</p> <p>Note 1: Particle, Stain or Linear Object that can be clean out easily within 3 times is disregarded.</p> <p>Note 2: All dimensions are in mm unless otherwise specified.</p>		

Item	Name of Defect	Definition
1	Dimension	D: Average Diameter; W: Width; L: Length; T: Glass Thickness
2	Inspection Area	According to engineering drawing, Viewable Area is the Inspection Area. Any defect outside of the Viewable Area may be disregarded.
3	Stain	No clear outline, not easy to identify with eyes, but able to clean out by wiping.
4	Interference Pattern	No clear outline, not easy to identify with eyes and unable to clean out by wiping.

[Appendix II]

Durability Testing Method

1. Finger Touch:

- ④ Test Position: Center of Active Area (Fig. 1)
- ④ Test pen: R8.0 Silicon Rubber (Fig. 2)
- ④ Test Method: Knock at the same location.

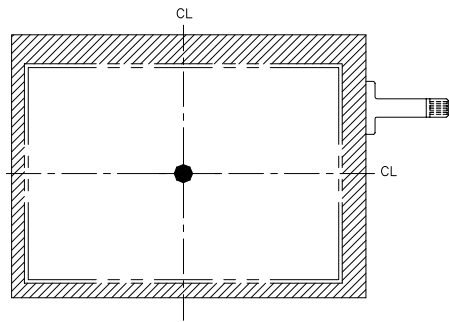

[Fig. 1]

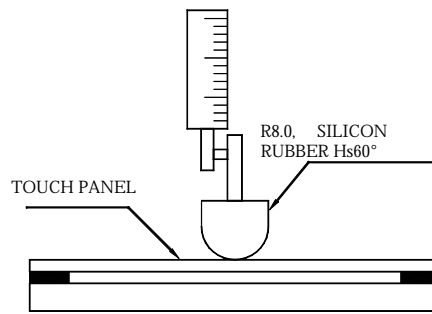

[Fig. 2]

2. Pen Sliding:

- ④ Test Position: Center of Active Area 20mm×20mm (Fig. 3)
- ④ Test Pen: R0.8 polyacetal Stylus (Fig. 4)
- ④ Test Method: Draw lines at the same location.

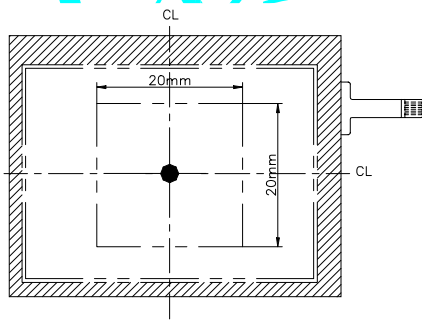

[Fig. 3]

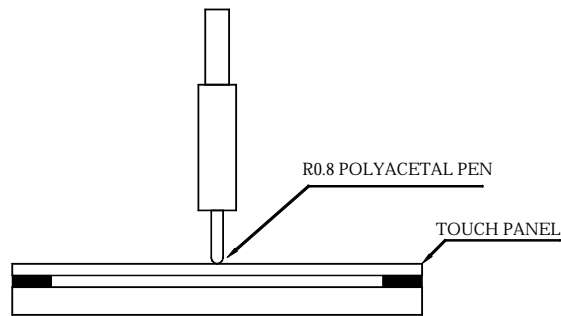

[Fig. 4]

Cautions for Product Handling

Note: To prevent malfunction as a result of improper handling of touch panel product, please make sure that the following instructions are followed:

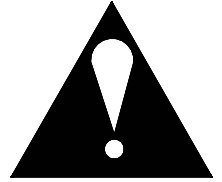

[Appendix III]

- 1、Wear gloves at all time upon handling touch panel, and hold touch panel only at the edge of the panel.
- 2、Use only the standard polyacetal rod pen (with a radius of 0.8 at the end of the rod) for product testing.
(Fig: 1,2,3)

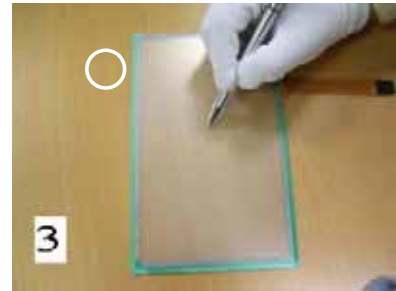
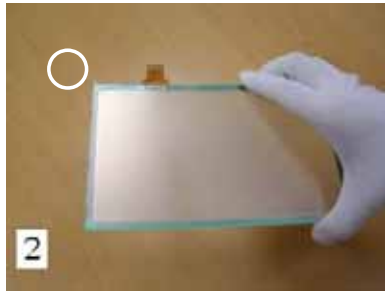

- 3、Do not lift touch panel via the connector (Tail). [Excess force applied on the Tail may cause displacement of the connector or cracks at the base of the panel.] (Fig: 4,5,6)
- 4、Do not handle the touch panel via the surface of the panel. [Excess force applied on the touch panel may crack the glass layer of the touch panel.] (Fig: 7,8)
- 5、Do not pile up touch panels together or place heavy substance on the touch panel. [Excess stress on the touch panel may scratch the surface of the touch panel, or crack the touch panel.] (Fig:9,10)
- 6、Do not touch the surface of the touch panel via sharp objects. [Sharp objects may cause scratch on the surface of the touch panel.] (Fig: 11)
- 7、Do not place the face of the film on the table or any other surface. [Various objects on the table may scratch the surface of the touch panel.] (Fig: 12)

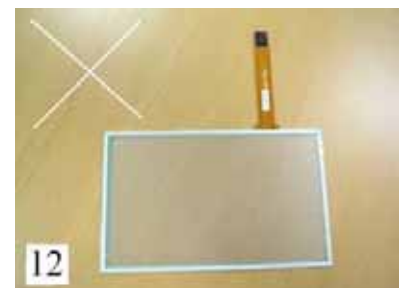
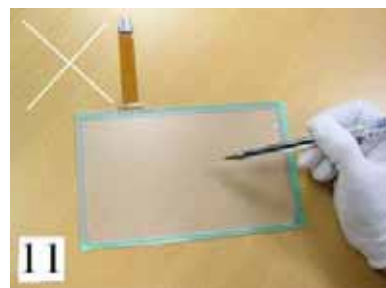
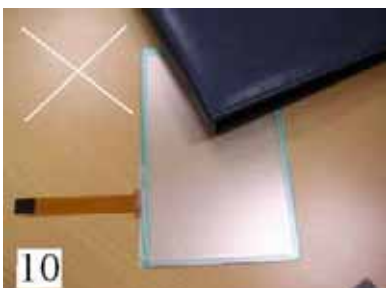
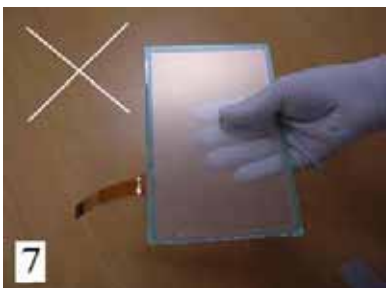
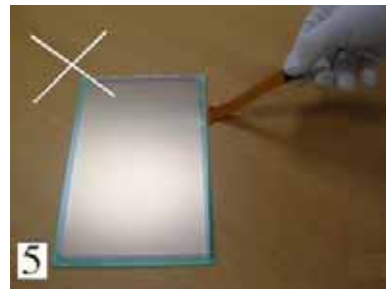
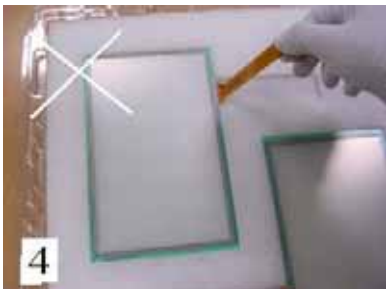

[Appendix IV]

Packing Method

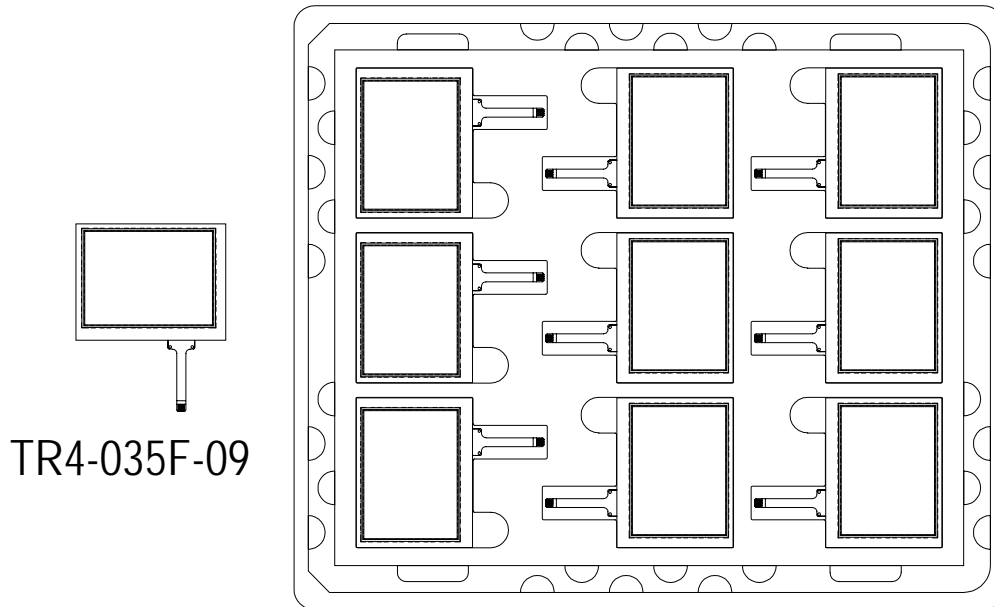

9PCS of T/P per Tray

Confidential

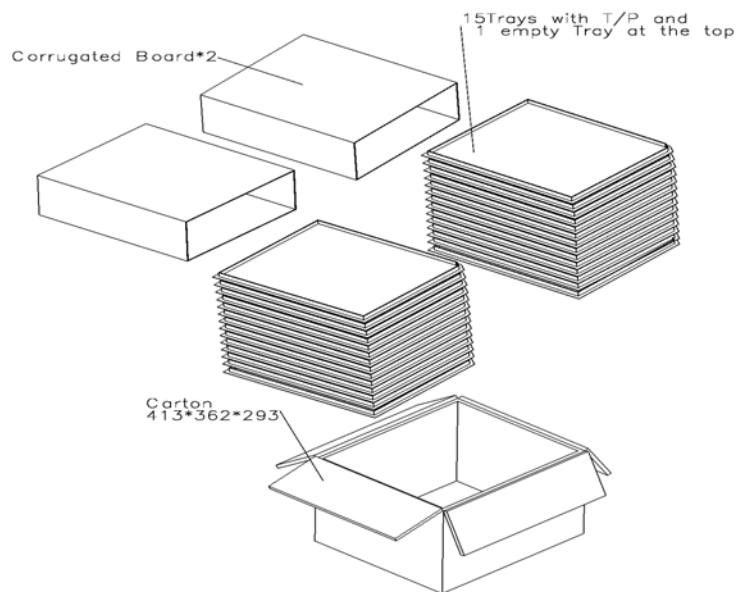

Packing Qty: 270 pcs per carton.